

Haier

Microwave Oven
Horno Microondas
Four Micro-ondes
MWG7036RW / B

Owner's Manual
Manual del Usuario
Manuel D'Utilisation

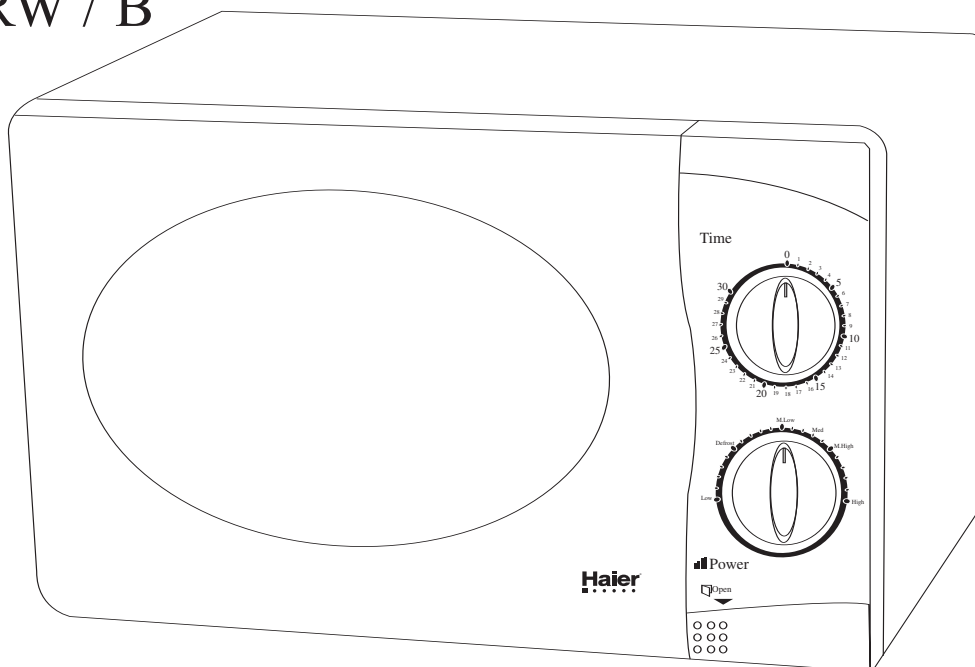

1. READ these instructions carefully before installing and operating the oven. Keep them for further reference.
2. Record in the space below the SERIAL NO. found on the nameplate on your oven and retain this information for future reference.

SERIAL NO:

1. LISEZ attentivement ces instructions avant d'installer et de faire fonctionner le four. Conservez-les en vue d'un usage ultérieur.
2. Inscrivez dans l'espace ci-dessous le N° DE SÉRIE figurant sur la plaque d'identification commerciale de votre four et conservez cette information pour pouvoir y revenir ultérieurement.

N° DE SÉRIE:

1. LEA LAS instrucciones cuidado samente antes de instalar y operar el microondas. Conserve el manual para mayor referencia.
2. Escriba en el espacio inferior el No. de serie que se encuentra en la placa del horno microondas y guarde esta información [ara referencia futura.

NUMERO DE SERIE:

PRECAUTIONS TO AVOID POSSIBLE EXPOSURE TO EXCESSIVE MICROWAVE ENERGY

- (a) Do not attempt to operate this oven with the door-open since open-door operation can result in harmful exposure to microwave energy. It is important not to defeat or tamper with the safety interlocks.
- (b) Do not place any object between the oven front face and the door or allow soil or cleaner residue to accumulate on sealing surfaces.
- (c) Do not operate the oven if it is damaged. It is particularly important that the oven door close properly and that there is no damage to the :
 - 1 Door (bent),
 - 2 Hinges and latches (broken or loosened),
 - 3 Door seals and sealing surfaces.
- (d) The oven should not be adjusted or repaired by anyone except properly qualified service personnel.

CONTENTS

PRECAUTIONS TO AVOID POSSIBLE EXPOSURE TO EXCESSIVE MICROWAVE ENERGY	1
IMPORTANT SAFETY INSTRUCTIONS	2
GROUNDING INSTRUCTIONS.....	3
UTENSILS GUIDE	4
COOKING TECHNIQUES	5
BEFORE YOU CALL FOR SERVICE	6
SPECIFICATIONS	6
PART NAMES	6
CONTROL PANEL.....	7
OPERATION INSTRUCTIONS	7
FOOD FACTS IN MICROWAVE COOKING	8
PROPER MICROWAVE OVEN CARE AND CLEANING	8
TROUBLESHOOTING	9
LIMITED WARRANTY	10

IMPORTANT SAFETY INSTRUCTIONS

When using electrical appliances, basic safety precautions should be followed, including the following:

WARNING - To reduce the risk of burns, electric shock, fire, injury to persons or exposure to excessive microwave energy:

1. **Read all instructions before using the appliance.**
2. Read and follow the specific "PRECAUTIONS TO AVOID POSSIBLE EXPOSURE TO EXCESSIVE MICROWAVE ENERGY" on page 2.
3. This appliance must be grounded. Connected only to properly grounded outlet. See "GROUNDING INSTRUCTIONS" on page 4.
4. Install or locate this appliance only in accordance with the provided installation instructions.
5. Some products such as whole eggs and sealed containers, for example, closed glass jars may explode and should not be heated in this oven.
6. Use this appliance only for its intended use as described in this manual. Do not use corrosive chemicals or vapors in this appliance. This type of oven is specifically designed to heat, cook or dry food. It is not designed for industrial or laboratory use.
7. As with any appliance, close supervision is necessary when used by children.
8. To reduce the risk of fire in the oven cavity:
 - a. Do not overcook food. Carefully attend appliance if paper, plastic or other combustible materials are placed inside the oven to facilitate cooking.
 - b. Remove wire twist-ties from paper or plastic bags before placing bag in oven.
 - c. If materials inside the oven should ignite, keep oven door closed, turn oven off, and disconnect the power cord or shut off power at the fuse or circuit breaker panel.**
 - d. Do not use the cavity for storage purposes. Do not leave paper products, cooking utensils or food in the cavity when not in use.
9. Liquids, such as water, coffee, or tea are able to be overheated beyond the boiling point without appearing to be boiling. Visible bubbling or boiling when the container is removed from the microwave oven is not always present. THIS COULD RESULT IN VERY HOT LIQUIDS SUDDENLY BOILING OVER WHEN THE CONTAINER IS DISTURBED OR A UTENSIL IS INSERTED INTO THE LIQUID.
10. Do not deep fry food in the microwave. It is difficult to control the fat which could cause a fire hazard.
11. Pierce foods with heavy skins such as potatoes, whole squash, apples and chestnuts before cooking.
12. The contents of feeding bottles and baby jars should be stirred or shaken and the temperature should be checked before serving in order to avoid burns.
13. Cooking utensils may become hot because of heat transferred from the heated food. Potholders may be needed to handle the utensil.
14. Do not cover or block any openings on the appliance.
15. Do not store or use this appliance outdoors. Do not use this product near water, for example, near a kitchen sink, in a wet basement, or near a swimming pool, and the like.
16. Do not operate this appliance if it has a damaged cord or a plug, if it is not working properly or if it has been damaged or dropped.
17. Do not immerse cord or plug in water. Keep cord away from heated surface. Do not let cord hang over edge of table or counter.
18. Use only thermometers which are specifically designed for use in microwave ovens.
19. Do not operate any heating or cooking appliance beneath this appliance.
20. Be certain the glass tray and roller ring are in place when you operate the oven.
21. This appliance should be serviced only by qualified service personnel. Contact nearest authorized service facility for examination, repair, or adjustment.

SAVE THESE INSTRUCTIONS

GROUNDING INSTRUCTIONS

This appliance must be grounded. In the event of an electrical short circuit, grounding reduces risk of electric shock by providing an escape wire for the electric current.

WARNING: Improper use of the grounding plug can result in a risk of electric shock.

Electrical Requirements

The oven must be plugged into at least 15 amp, 120 volts, 60 Hz grounded outlet. It is recommended that a separate circuit serving only the oven be provided. The oven is equipped with a 3-prong grounding plug. It must be plugged into a wall receptacle that is properly installed and grounded.

Extension Cord

We do not recommend to use an extension cord. If it is necessary to use an extension cord, use only a 3-wire extension cord that has a 3 blade grounding plug and a 3-slot receptacle that will accept the plug on the microwave oven. The marked rating of the extension cord shall be equal to or greater than the electrical rating of the appliance.

- Notes:**
1. If you have any questions about the grounding or electrical instructions, consult a qualified electrician or service person.
 2. Neither Haier nor the dealer can accept any liability for damage to the oven or personal injury resulting from failure to observe the electrical connection procedures.

Radio or TV Interference

Should there be any interference caused by the microwave oven to your radio or TV, check that the microwave oven is on a different circuit, relocate the radio or TV as far away from the oven as feasible or check position and signal of receiving antenna.

INSTALLATION INSTRUCTIONS

Select a level surface that provides enough open space for the intake and/or outlet vents. A minimum clearance of 3 inches is required between the oven and any adjacent wall. One side must be open. Leave a minimum clearance of 3 inches above the oven. Do not cover or block any openings on the appliance. Do not remove feet from the bottom of the oven.

UTENSILS GUIDE

This section lists which utensils can be used in the microwave, which ones have limited use for short periods, and which ones should not be used in the microwave.

Recommended

- **Microwave browning dish** - Use to brown the exterior of small items such as steaks, chops, or pancakes. Follow the directions provided with your browning dish.
- **Microwaveable plastic wrap** - Use to retain steam. Leave a small opening for some steam to escape and avoid placing it directly on the food.
- **Paper towels and napkins** - Use for short-term heating and covering; these absorb excess moisture and prevent spattering. Do not use recycled paper towels, which may contain metal and could ignite.
- **Glass and glass-ceramic bowls and dishes** - Use for heating or cooking.
- **Paper plates and cups** - Use for short-term heating at low temperatures. Do not use recycled paper, which may contain metal and could ignite.
- **Wax paper** - Use as a cover to prevent spattering.
- **Thermometers** - Use only those labeled "Microwave Safe" and follow all directions. Check the food in several places. Conventional thermometers may be used on microwave food once the food has been removed from the oven.

Limited Use

- Ceramic, porcelain, and stoneware - Use these if they are labeled "Microwave Safe".
- Plastic - Use only if labeled "Microwave Safe". Other plastics can melt.
- Straw, wicker, and wood - Use only for short-term heating, such as warming dinner rolls for a few seconds; baskets and bowls may be flammable.

Not Recommended

- Glass jars and bottles - Regular glass is too thin to be used in a microwave. It can shatter and cause damage and injury.
- Paper bags - These are a fire hazard, except for popcorn bags that are designed for microwave use.
- Styrofoam plates and cups - These can melt and leave an unhealthy residue on food.
- Plastic storage and food containers - Containers such as margarine tubs can melt in the microwave.
- Metal utensils - These can damage your oven. Remove all metal before cooking.

Note: Should you wish to check if a dish is safe for microwaving, place the empty dish in the oven and microwave on HIGH for 30 seconds. A dish which becomes very hot should not be used.

COOKING TECHNIQUES

Your microwave makes cooking easier than conventional cooking, provided you keep these considerations in mind:

Stirring

Stir foods such as casseroles and vegetables while cooking to distribute heat evenly. Food at the outside of the dish absorbs more energy and heats more quickly, so stir from the outside to the center. The oven will turn off when you open the door to stir your food.

Arrangement

Arrange unevenly shaped foods, such as chicken pieces or chops, with the thicker, meatier parts toward the outside of the turntable where they receive more microwave energy. To prevent overcooking, place delicate areas, such as asparagus tips, toward the center of the turntable.

Shielding

Shield food with narrow strips of aluminum foil to prevent overcooking. Areas that need shielding include poultry wing-tips, the ends of poultry legs, and corners of square baking dishes. Use only small amounts of aluminum foil. Larger amounts can damage your oven.

Turning

Turn foods over midway through cooking to expose all parts to microwave energy. This is especially important with large foods such as roasts.

Standing

Foods cooked in the microwave build up internal heat and continue to cook for a few minutes after heating stops. Let foods stand to complete cooking, especially foods such as cakes and whole vegetables. Roasts need this time to complete cooking in the center without overcooking the outer areas. All liquids, such as soup or hot chocolate, should be shaken or stirred when cooking is complete. Let liquids stand a moment before serving. When heating baby food, stir well at removal and test the temperature before serving.

Adding moisture

Microwave energy is attracted to water molecules. Food that is uneven in moisture content should be covered or allowed to stand so that the heat disperse evenly. Add a small amount of water to dry food to help it cook.

BEFORE YOU CALL FOR SERVICE

If the oven fails to operate:

- A) Check to ensure that the oven is plugged in securely. If it is not, remove the plug from the outlet, wait 10 seconds and plug it in again securely.
- B) Check for a blown circuit fuse or a tripped main circuit breaker. If these seem to be operating properly, test the outlet with another appliance.
- C) Check to ensure that the control panel is programmed correctly and the timer is set.
- D) Check to ensure that the door is securely closed engaging the door safety lock system. Otherwise, the microwave energy will not flow into the oven.

IF NONE OF THE ABOVE RECTIFY THE SITUATION, THEN CONTACT A QUALIFIED TECHNICIAN. DO NOT TRY TO ADJUST OR REPAIR THE OVEN YOURSELF.

SPECIFICATIONS

Power Consumption:	120V~60Hz, 1200W
Output:	700W
Operation Frequency:	2450MHz
Outside Dimensions(HxWxD):	11 5/8 x 18 1/16 x 14 1/16 in.
Oven Cavity Dimensions(HxWxD):	8 1/8 x 11 13/16 x 11 3/16 in.
Oven Capacity:	0.6 cu. Ft.
Cooking Uniformity:	Turntable System (10 5/8")
Net Weight:	Approx. 30.2 lbs.

PART NAMES

- 1 Door Safety Lock System
- 2 Oven Window
- 3 Oven Air Vent
- 4 Shaft

- 5 Roller Ring
- 6 Glass Tray
- 7 Control Panel
- 8 Door Release Button

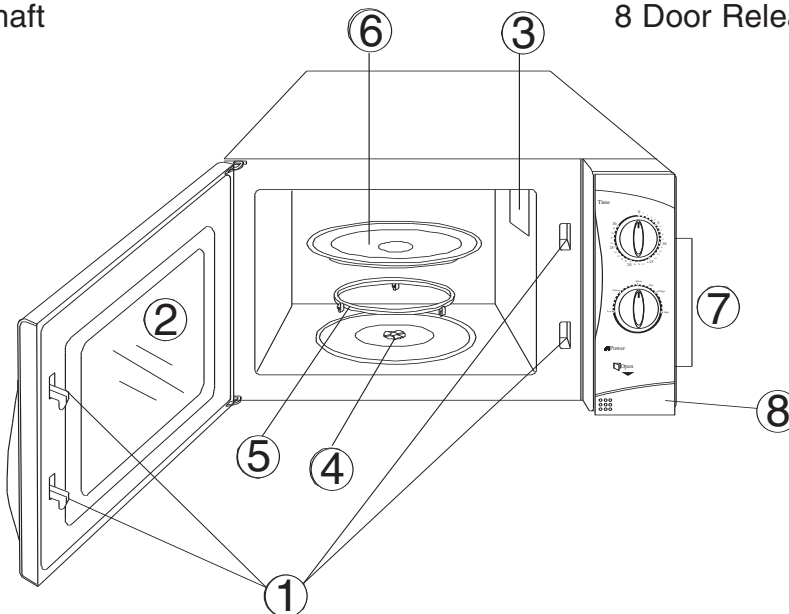

CONTROL PANEL

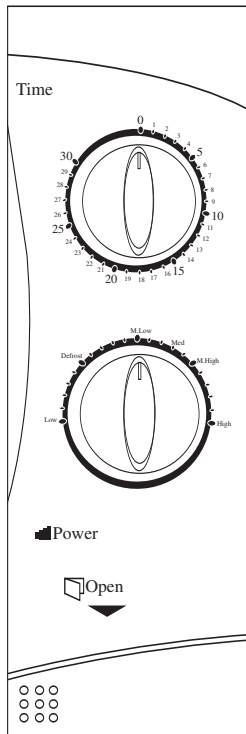

- 1) Timer (0-30 minutes)
- 2) Power Select Control

HIGH	100% Power Output
M.HIGH	85% Power Output
MED	66% Power Output
M.LOW	48% Power Output
DEFROST	40% Power Output
LOW	17% Power Output

OPERATION INSTRUCTIONS

To start a cooking program: PLACE CONTAINER OF FOOD on the glass tray and close the door.

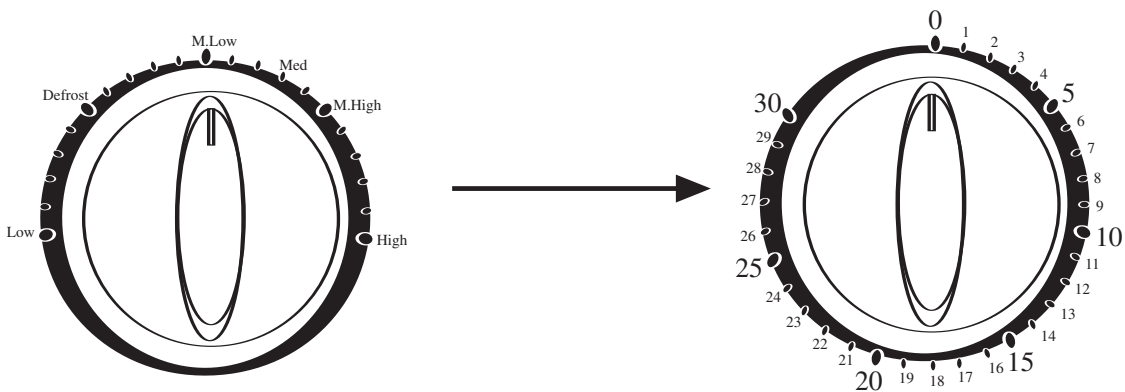

Note: As soon as the timer is turned, oven will start cooking. When setting timer for less than 2 minutes, turn timer past 2 minutes and then return to correct time. When time has elapsed, a bell will ring and the unit will turn off.

CAUTION: ALWAYS RETURN TIMER BACK TO ZERO POSITION if food is removed from oven before the set cooking time is complete or when oven is not in use. You may open the door while the oven is operating. As soon as the door is opened the safety mechanism stops microwave power.

Food Facts in Microwave Cooking

The quality of the food: Poor quality ingredients are rarely improved by any method of cooking and this applies particularly to microwave cooking, as the process is so fast.

Temperature: The colder the food before cooking, the longer it will take to cook.

Quantity: The cooking time relates to the amount of food in the microwave oven. Do not overload the microwave. For very large quantities, it is better and may be quicker to cook in two or more batches.

Density: The more porous the food, the faster it will cook. A light airy cake mixture will cook faster than jacket potatoes. **Size and Shape:** Uniform shapes cook more evenly. In an irregular shape, such as a leg of lamb, the thinner parts will cook faster than the thick part. The smaller the individual piece of food is (such as the vegetables in a soup) the quicker the cooking.

Moisture: There is very little evaporation in microwave cooking so foods can be cooked in the minimum water. Casseroles need about half the usual amount of stock; vegetables need only two or three tablespoons of water.

Bones: Meat and poultry bones conduct heat, therefore the areas around them will cook faster than the rest of the meat. Insert a microwave meat thermometer into the thickest part of the flesh away from any bone for an accurate grading.

Proper Microwave Oven Care and Cleaning

Warning: To avoid electric shock always unplug your microwave oven before cleaning. Ignoring this warning may result in death or injury.

Caution: Before using cleaning products, always read and follow manufacturer's instructions and warnings to avoid personal injury or product damage.

General:

- Prepare a cleaning solution of 3-4 tablespoons of baking soda mixed with warm water. Use sponge or soft cloth, dampened with the cleaning solution, to wipe down your microwave oven.
- Rinse with clean warm water and dry with a soft cloth.
- Do not use harsh chemicals, abrasives, ammonia, chlorine bleach, concentrated detergents, solvents or metal scouring pads. SOME of these chemicals may dissolve, damage and/or discolor your microwave oven.
- Keep the inside of the oven clean. When food spatters or liquid spills, wipe with a damp cloth.
- To prevent damage to the operating parts inside the oven, care should be taken so water does not sweep into the ventilation openings.
- Care should be taken in cleaning the touch control panel. If the control panel becomes soiled, open the oven door before cleaning. Wipe the panel with a cloth dampened slightly with water only. Dry with a soft cloth. Do not scrub or use any sort of chemical cleaners. Close door and touch STOP/CLEAR.
- If steam accumulates inside or around the outside the oven door, wipe with a soft cloth. This may occur when the microwave oven is operated under high humidity conditions and in no way indicates a malfunction of the unit.
- The turntable and oven cavity floor should be cleaned regularly. Simply wipe the bottom surface of the oven and dry. The turntable may be washed in mild sudsy water or in the dishwasher.

Troubleshooting

Questions and Answers:

- Q. Accidentally running of microwave oven without any food in it. Is it damaged?
- A. We do not recommend operating the microwave oven without any food, however, running the oven empty for a short time will not damage the oven.
- Q. What if oven does not turn on?
- A. Check the following:
- 1) Is the oven plugged in securely? Remove plug from the outlet, wait 10 seconds and reinsert.
 - 2) Check circuit breaker or fuse. Reset circuit breaker or replace fuse if it is tripped or blown.
- Q. Can the oven be used with the glass tray removed?
- A. No. The glass tray must be positioned correctly in the oven before cooking.
- Q. Why does warm air come from the oven vents and steam accumulates on the oven door?
- A. This is due to heat being given off from food cooking in the oven cavity. The warm air is carried out of the oven by the airflow pattern in the oven. There are no microwaves in the air. The oven vents should never be blocked during cooking. During cooking time, steam is given off from the food. Most of the steam is removed from the oven by the air; which circulates in the oven cavity. However, some steam will condense on cooler surfaces such as the oven door. This is normal.
- Q. My microwave causes interference on my TV. Is this Normal?
- A. Some Radio and TV interference might occur when you cook with the microwave oven. This interference is similar to the interference caused by small appliances such as mixers, vacuums, blow dryers, etc. It does not indicate a problem with your oven.
- Q. Can TV dinner trays be placed in the oven?
- A. Only TV dinners labeled microwave safe are recommended for this oven. Make sure foil covers are removed from top of container.

Limited Warranty

What is covered and for how long?

This warranty covers the original retail purchaser, all defects in workmanship or materials for a period of:

Carry-In Service

12 Months (labor)

24 Months (parts)

10 Years Magnetron Tube (part only)

What is covered.

1. The mechanical and electrical parts, which serve as a functional purpose of this appliance for a period of 24 months. This includes all parts except glass, finish, and trim.
2. If the magnetron tube fails due to poor workmanship or material, the part will be replaced.

What will be done and how to obtain service?

1. We will repair or replace, at our discretion any mechanical or electrical part which proves to be defective in normal usage during the warranty period so specified.
2. There will be no charge to the purchaser for labor on any covered items during the initial 12 month period, and no charge for parts on any covered items during the initial 24 month period. The magnetron tube is covered for a period of ten years.
3. To obtain service, bring the unit to your nearest authorized Service depot. For name of the nearest authorized service center please call: 1-877-337-3639.

THIS WARRANTY COVERS APPLIANCES WITHIN THE CONTINENTAL UNITED STATES, CANADA AND PUERTO RICO. IT DOES NOT COVER THE FOLLOWING:

Damages from improper installation.

Damages in shipping.

Damage from misuse, abuse, accident, alteration, lack of proper care and maintenance, incorrect current or voltage or acts of God.

Damage from other than normal household use.

Damage from service by other than an authorized dealer or service center.

Decorative trims, glass or light bulbs.

Transportation and shipping costs.

THIS LIMITED WARRANTY IS GIVEN IN LIEU OF ALL OTHER WARRANTIES, EXPRESSED OR, INCLUDING THE WARRANTIES OF MERCHANTABILITY AND FITNESS FOR A PARTICULAR PURPOSE.

The remedy provided in this warranty is exclusive and is granted in lieu of all other remedies.

This warranty does not cover incidental or consequential damages, so the above limitations may not apply to you. Some States do not allow limitations on how long an implied warranty lasts, so the above limitations may not apply to you.

This warranty gives you specific legal rights, and you may have other rights, which vary, from state to state.

Haier America
New York, NY 10018

IMPORTANT

Do Not Return This Product To The Store

**If you have a problem with this product, please contact the "Haier Customer Satisfaction Center" at
1-877-337-3639.**

DATED PROOF OF PURCHASE REQUIRED FOR WARRANTY SERVICE

IMPORTANTE

No regrese este producto a la tienda

**Si tiene algún problema con este producto, por favor contacte el "Centro de Servicio al Consumidor de
Haier" al 1-877-337-3639 (Válido solo en E.U.A).**

NECESITA UNA PRUEBA DE COMPRA FECHADA PARA EL SERVICIO DE LA GARANTIA

IMPORTANT

No regrese este producto a la tienda

**Si tiene algún problema con este producto, por favor contacte el "Centro de Servicio al Consumidor de
Haier" al 1-877-337-3639 (Válido solo en E.U.A).**

NECESITA UNA PRUEBA DE COMPRA FECHADA PARA EL SERVICIO DE LA GARANTIA

Haier

**Haier America
New York, NY 10018**